

CRANE-SHOVEL, BASIC UNIT, TRUCK MOUNTED: 20 TON, 3/4
CU. YD; GASOLINE ENGINE, 6X6 (AMERICAN HOIST &
DERRICK MODELS W-2360 (WINTERIZED) & 2360
(NON-WINTERIZED) W/CONTINENTAL ENGINE
MODELSS749 (CARRIER) BS415 (CRANE)

Reference: LO 5-3810-227-15-1, -2, and -4 C 9100-SL

Intervals are based on normal hours of operations. Reduce to compensate for abnormal operations and severe conditions. During inactive periods, sufficient lubrication must be performed for adequate preservation.

Clean fittings before lubricating.
Relubricate after washing or fording.

Clean ports with SOLVENT, dry-cleaning, or with OIL, fuel, Diesel. Dry before lubricating.

Lubricate points indicated by dotted arrow shafts on both sides of equipment.

LUBRICANT • INTERVAL

INTERVAL • LUBRICANT

Control Levers and Brake Pedal Bushings GAA

Hoist Drum Brake Shaft Bushings GAA

Boom Hoist Control Bellcrank GAA

Swing Control Bellcrank GAA

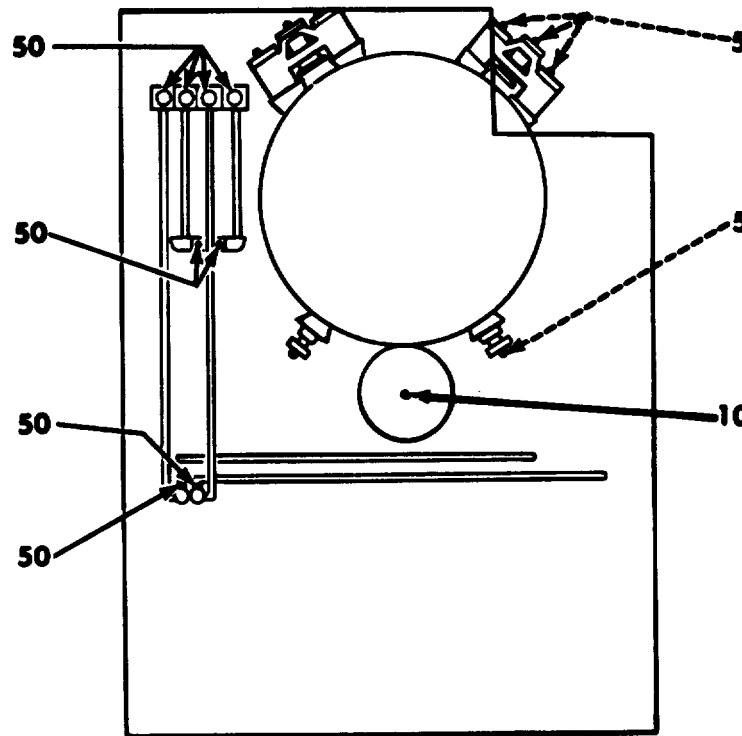

GAA Front Load Roller Bushings

GAA Rear Load Roller Bushings

GAA Vertical Reversing Shaft Bearing

CONTROLS AND ROLLERS

LUBRICANT • INTERVAL

INTERVAL • LUBRICANT

Guide Roller Bushings OE 10
(Oil can point.)

Boom Point Sheaves GAA 10
(3 fittings.)

Boom Foot Bushings GAA 10

GAA Vertical Crossover sheave Bushing (2 fittings each side.)

GAA Horizontal crossover sheave Bushing

CW-11 Cables (See note 3.)

GAA Bridle sheave Bushings

GAA Bridle Anchor bearing

GAA Vertical Gantry Sheave Bushings (3 fittings.)

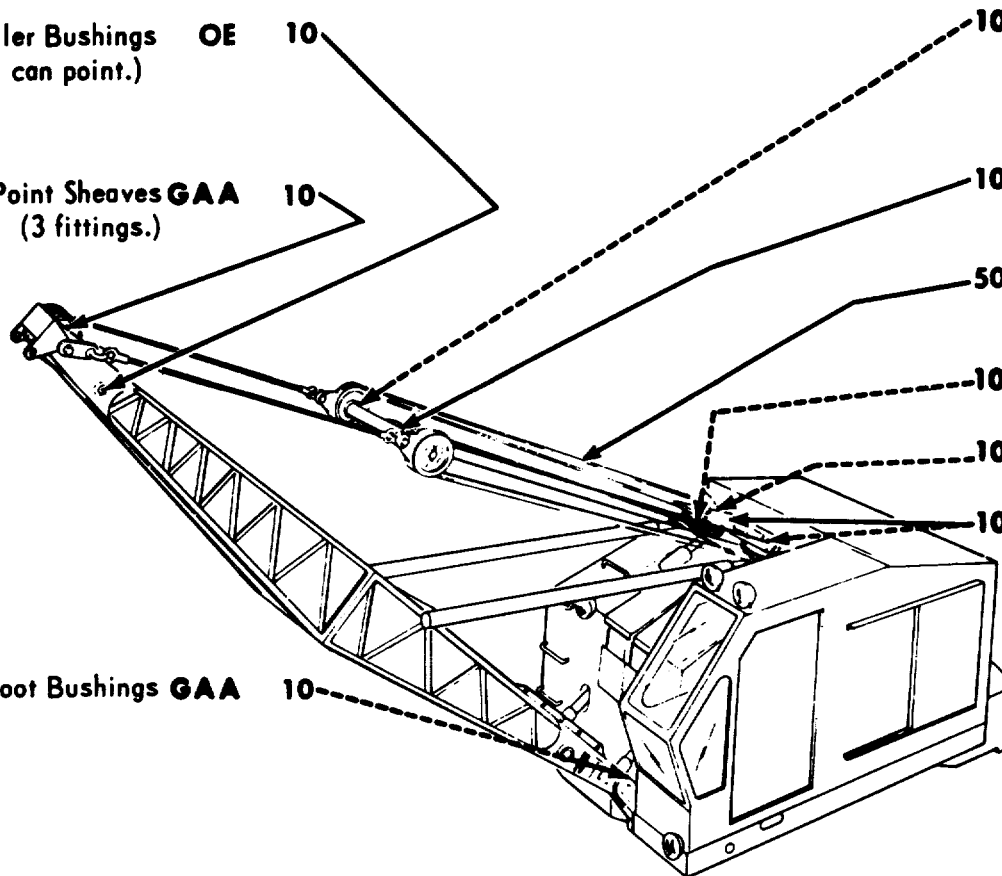

BOOM AND GANTRY

- KEY -

LUBRICANTS	CAPACITY	EXPECTED TEMPERATURES			INTERVALS
		Above +32°F	+40°F to -10°F	0°F to -65°F	
OE-OIL, Engine, Heavy Duty		OE 30	OE 10		Intervals given are in hours of normal operation.
Oil Can Points		or	or	OES	
OES-OIL, Engine, Sub-zero		9250	9110		
CW-11-LUBRICATING OIL, Exposed Gear		All Temperatures			
GAA-GREASE, Automotive and Artillery					

- NOTES:**
- FOR OPERATION OF EQUIPMENT IN PROTRACTED COLD TEMPERATURES BELOW -100F. Remove lubricants prescribed in the key for temperatures above -100F. Clean ports with SOLVENT, dry-cleaning. Relubricate with lubricants specified in the key for temperatures below -100F.
 - OIL CAN POINTS.** Every 50 hours lubricate control linkages, pins and clevises, and all exposed adjusting threads with OE.
 - CABLES.** Every 50 hours clean and coat all cables with CW11 except those coming in constant contact with dirt or excavated materials.
- Copy of this Lubrication Order will remain with the equipment at all times; instructions contained herein are mandatory.
- BY ORDER OF THE SECRETARY OF THE ARMY:
 EARLE G. WHEELER,
 General, United States Army,
 Chief of Staff.
- OFFICIAL:
 J. C. LAMBERT,
 Major General, United States Army,
 The Adjutant General.

LO 5-3810227-15-3 DISTRIBUTION: Active Army; USASA (2); ACSI (1); DCSLOG (1); CNGB (1); TSG(1); CofEngrs (3); CSigO (1); CofT (1); CofSptS (1); army Maint Bd (1) USAARTBD (2); USAARMBD (2); USAIB (2); USAADBD (2); USAAESWB (2); USCONARC (3); OS Maj Comd (5) except USARJ (10); USAMOCOM (2); USASCOM (1); MDW (1); Armies (2); Corps (2); Div (2); Engr Bde (1); Svc College (2); Br Svc Sch (2) except USAES (100); USMA (2); GENDEP (OS) (10); Engr Dep (OS); Army Dep (2); Trans Tml comd (2); Army Tml Comd (1); USAOSA (2) Div Engr (2); Dist Engr (2); USAERDL (3); USA Mbl Spt Cen (10); Engr Cen (5); USAREUR Engr Proc Cen (2); USAREUR Engr Sup Con agcy (10); Chicago Proc (10); Engr Fld Maint Shops (2); ESCO (10); Fld Comd, DASA (8); AS (3); USAREURCOMZ (2); USA Corps (1); MAAG (1); JBUSMC (1) units org under fol TOE: (2 copies each 3-117, 5-5, 5-6, 5-8, 5-15, 5-16, 5-35, 5-36, 5-45, 5-46, 5-48, 5-54, 5-77, 5-78, 5-114, 5-115, 5-117, 5-118, 5-127, 5-129, 5-177, 5-214, 5-237, 5-267, 5-278, 5-279, 5-500 (BA, BB, BC, EA, E, EG), 6-635, 7-100, 9-9, 9-17, 9-47, 9-57, 9-87, 9-167, 9-217, 9-227, 9-367, 9-377, 10-377, 17-100, 29-105, 29-107, 37-100, 39-61, 5-117, 55-260, 55-445, 55-468, 55-469, 55-500 (JB), 57-100. NG: State AG (3) USAR: Units - Same as Active Army except allowance is one copy for each unit. For explanation of abbreviations used, see AR 320-50.

RECOMMENDED CHANGES TO EQUIPMENT TECHNICAL PUBLICATIONS



THEN...JOT DOWN THE
DOPE ABOUT IT ON THIS FORM.
CAREFULLY TEAR IT OUT, FOLD IT
AND DROP IT IN THE MAIL.

SOMETHING WRONG WITH PUBLICATION

FROM: (PRINT YOUR UNIT'S COMPLETE ADDRESS)

DATE SENT

PUBLICATION NUMBER

PUBLICATION DATE

PUBLICATION TITLE

BE EXACT PIN-POINT WHERE IT IS

PAGE NO.	PARA-GRAPH	FIGURE NO.	TABLE NO.

IN THIS SPACE, TELL WHAT IS WRONG AND WHAT SHOULD BE DONE ABOUT IT.

PRINTED NAME, GRADE OR TITLE AND TELEPHONE NUMBER

SIGN HERE

The Metric System and Equivalents

Linear Measure

1 centimeter = 10 millimeters = .39 inch
 1 decimeter = 10 centimeters = 3.94 inches
 1 meter = 10 decimeters = 39.37 inches
 1 dekameter = 10 meters = 32.8 feet
 1 hectometer = 10 dekameters = 328.08 feet
 1 kilometer = 10 hectometers = 3,280.8 feet

Weights

1 centigram = 10 milligrams = .15 grain
 1 decigram = 10 centigrams = 1.54 grains
 1 gram = 10 decigrams = .035 ounce
 1 decagram = 10 grams = .35 ounce
 1 hectogram = 10 decagrams = 3.52 ounces
 1 kilogram = 10 hectograms = 2.2 pounds
 1 quintal = 100 kilograms = 220.46 pounds
 1 metric ton = 10 quintals = 1.1 short tons

Liquid Measure

1 centiliter = 10 milliliters = .34 fl. ounce
 1 deciliter = 10 centiliters = 3.38 fl. ounces
 1 liter = 10 deciliters = 33.81 fl. ounces
 1 dekaliter = 10 liters = 2.64 gallons
 1 hectoliter = 10 dekaliters = 26.42 gallons
 1 kiloliter = 10 hectoliters = 264.18 gallons

Square Measure

1 sq. centimeter = 100 sq. millimeters = .155 sq. inch
 1 sq. decimeter = 100 sq. centimeters = 15.5 sq. inches
 1 sq. meter (centare) = 100 sq. decimeters = 10.76 sq. feet
 1 sq. dekameter (are) = 100 sq. meters = 1,076.4 sq. feet
 1 sq. hectometer (hectare) = 100 sq. dekameters = 2.47 acres
 1 sq. kilometer = 100 sq. hectometers = .386 sq. mile

Cubic Measure

1 cu. centimeter = 1000 cu. millimeters = .06 cu. inch
 1 cu. decimeter = 1000 cu. centimeters = 61.02 cu. inches
 1 cu. meter = 1000 cu. decimeters = 35.31 cu. feet

Approximate Conversion Factors

<i>To change</i>	<i>To</i>	<i>Multiply by</i>	<i>To change</i>	<i>To</i>	<i>Multiply by</i>
inches	centimeters	2.540	ounce-inches	Newton-meters	.007062
feet	meters	.305	centimeters	inches	.394
yards	meters	.914	meters	feet	3.280
miles	kilometers	1.609	meters	yards	1.094
square inches	square centimeters	6.451	kilometers	miles	.621
square feet	square meters	.093	square centimeters	square inches	.155
square yards	square meters	.836	square meters	square feet	10.764
square miles	square kilometers	2.590	square meters	square yards	1.196
acres	square hectometers	.405	square kilometers	square miles	.386
cubic feet	cubic meters	.028	square hectometers	acres	2.471
cubic yards	cubic meters	.765	cubic meters	cubic feet	35.315
fluid ounces	milliliters	29.573	cubic meters	cubic yards	1.308
pints	liters	.473	milliliters	fluid ounces	.034
quarts	liters	.946	liters	pints	2.113
gallons	liters	3.785	liters	quarts	1.057
ounces	grams	28.349	liters	gallons	.264
pounds	kilograms	.454	grams	ounces	.035
short tons	metric tons	.907	kilograms	pounds	2.205
pound-feet	Newton-meters	1.356	metric tons	short tons	1.102
pound-inches	Newton-meters	.11296			

Temperature (Exact)

°F	Fahrenheit temperature	5/9 (after subtracting 32)	Celsius temperature	°C
----	---------------------------	-------------------------------	------------------------	----

PIN: 022452-000